



INSTALLATION INSTRUCTIONS

Accessory
TRAILER HITCH

Application
2011 ELEMENT

Publications No.
All 43513
Issue Date
OCT 2010

PARTS LIST

Trailer Hitch Kit
P/N 08L92-SCV-101

Trailer hitch

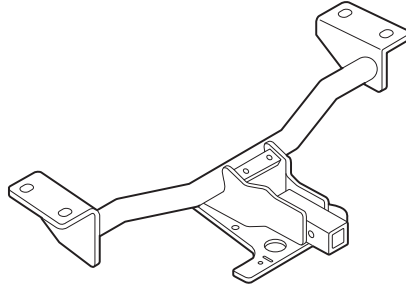

Left stay

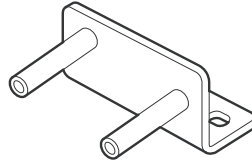

Right stay

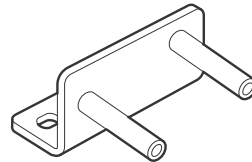

4 Side plates

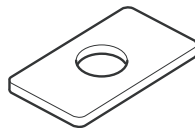

Ball mount

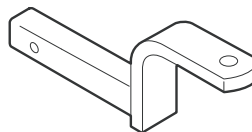

4 Bolts, 12 x 135 mm



4 Bolts, 12 x 35 mm



U-bolt

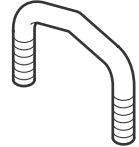

2 Nuts, 8 mm



2 Washers, 8 mm



2 Spring washers, 8 mm



8 Nuts, 12 mm



12 Washers, 12mm



8 Spring washers, 12 mm



Retaining pin

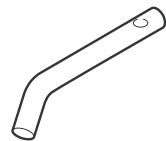

Retaining pin clip



Receiver cover

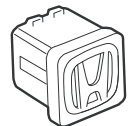

**Harness kit (sold separately)
P/N 08L91-SCV-100A**

Socket harness

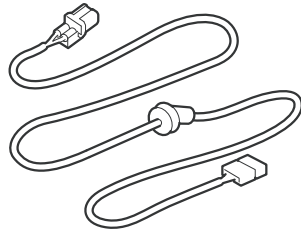

Control unit harness



Control unit

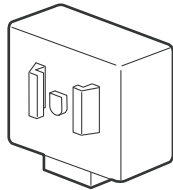

Connector bracket

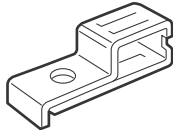

Control unit bracket

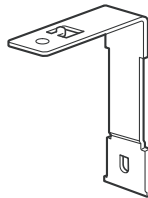

Flange nut



Flange bolt



8 Wire ties

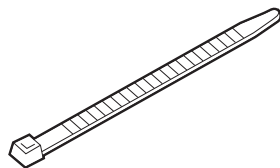

Wire tie with clip

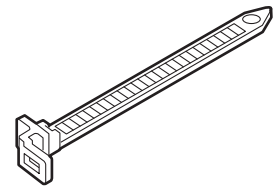

Fuse label

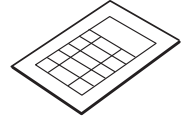

3 EPT sealers

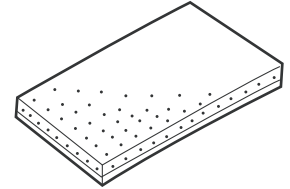

Accessory User's
Information Manual

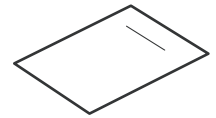

TOOLS AND SUPPLIES REQUIRED

Philips screwdriver

Flat-tip screwdriver

10 mm, 13 mm, 14 mm, 19 mm Combination wrenches

Torque wrench

Tape measure

Ratchet

Diagonal cutters

Piece of steel wire

Isopropyl alcohol

Shop towel

Cardboard or blanket

12 mm T-wrench

Clip remover

Utility knife

Scissors

INSTALLATION

Customer Information: The information in this installation instruction is intended for use only by skilled technicians who have the proper tools, equipment, and training to correctly and safely add equipment to your vehicle. These procedures should not be attempted by “do-it-yourselfers.”

1. Make sure you have the anti-theft code for the radio, then write down the frequencies for the preset buttons.
2. Disconnect the negative cable from the battery.

Routing the Socket Harness

3. Remove the rear bumper (two 4 x 20 mm self-tapping screws, two 5 x 16 mm self-tapping screws, two bolts, and two clips).

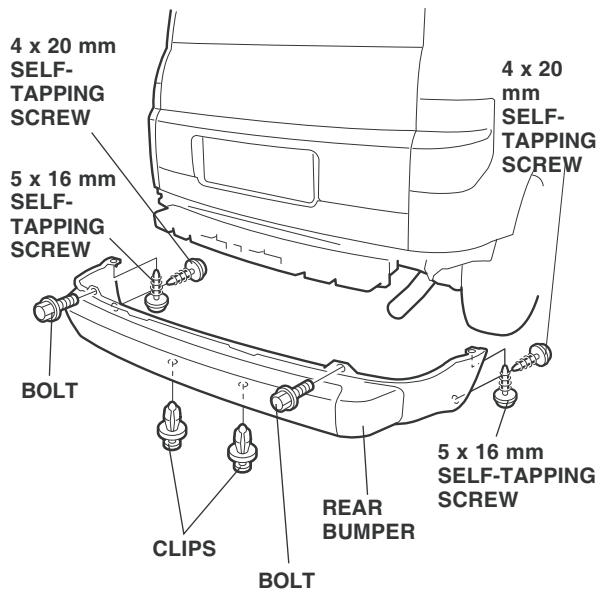

4. Open the upper and lower tailgates and take out the cargo area floor (two hooks).

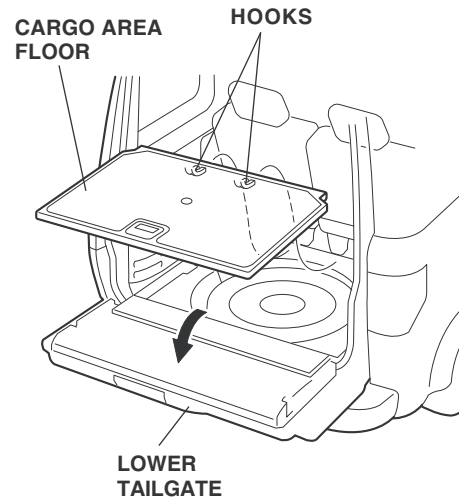

5. Attach two EPT sealers to the socket harness in the area shown.

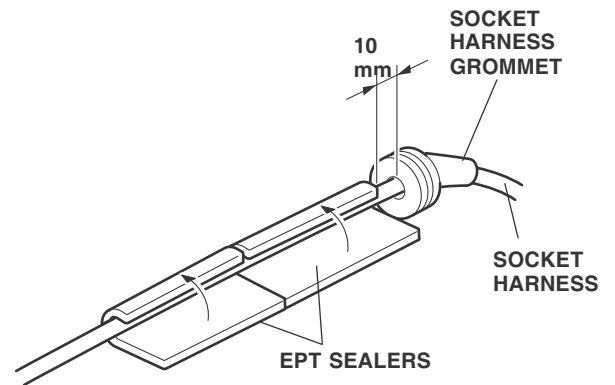

- On the inside of the cargo area, locate the plastic hole cover that is attached to the square hole in the inner panel. Bend up the lower half to the slit in the center.

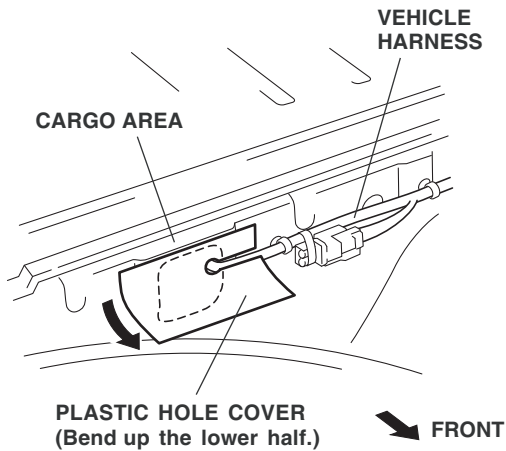

- Remove and discard the rear left grommet from the body. Attach a piece of steel wire to the socket harness 4-pin connector and route the 4-pin connector through the vehicle grommet hole and into the hole in the cargo area. Seat the socket harness grommet in the vehicle grommet hole with the end facing down.

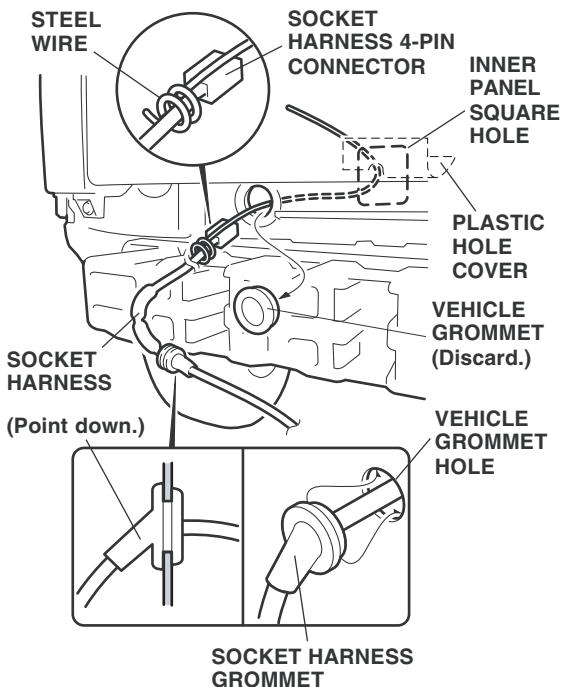

- Remove the steel wire from the socket harness 4-pin connector.

- Install a wire tie with clip to the socket harness 4-pin connector. Remove the blue tape to free the 4-pin connector on the vehicle harness in the cargo area. Remove the dummy connector from the 4-pin connector on the vehicle harness and connect the 4-pin connector on the socket harness. Secure the connected 4-pin connectors to the vehicle harness with a wire tie with clip, and wrap an EPT sealer around it.

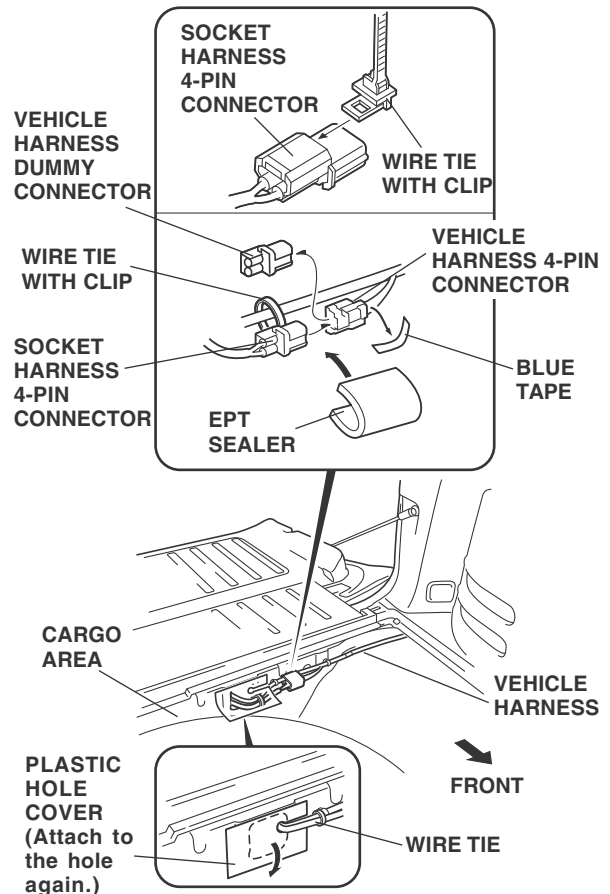

- Secure the socket harness to the vehicle harness with one wire tie as shown. Route the socket harness through the square hole in the inner panel and attach the plastic hole cover to the hole again.

- Route the socket harness down through the clearance between the rear bumper beam and the body panel. Reinstall the rear bumper.

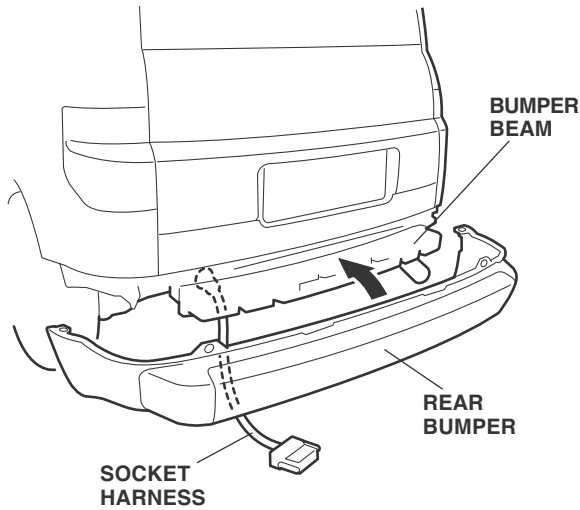

Routing the Control Unit Harness

- Remove the driver's dashboard lower cover, turn the knobs clockwise, then pull the lower cover out toward you to release the six retaining tabs.

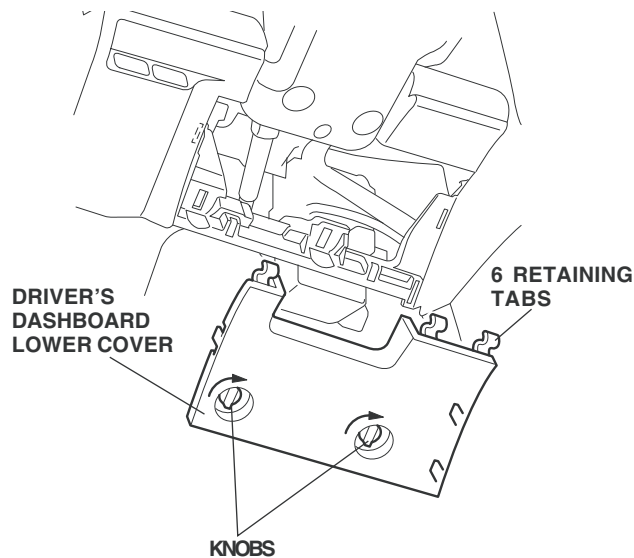

- Slide the unit bracket onto the control unit. Do not push on the connector area.

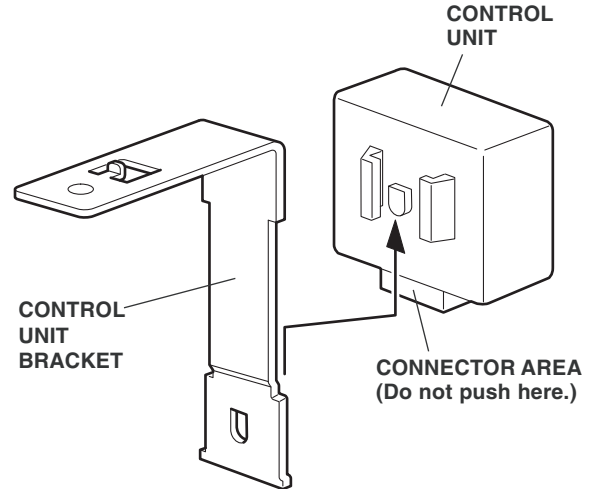

- Unplug the vehicle 5-pin connector from the keyless receiver unit. Remove the vehicle bracket (one bolt).

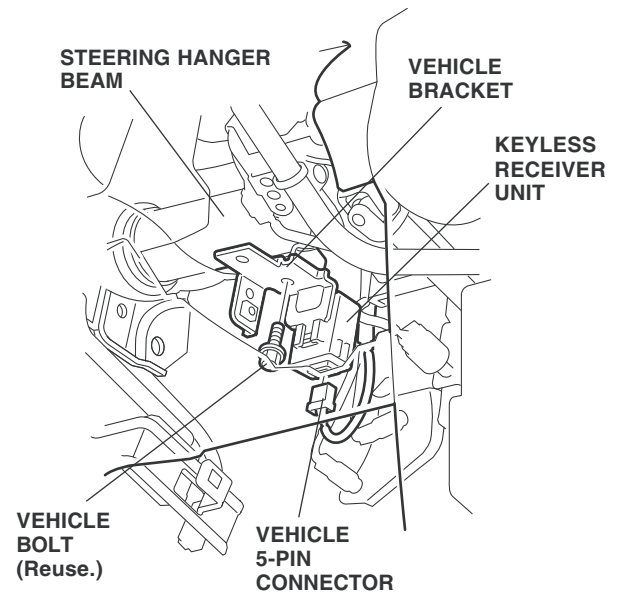

With Optional Security System:

- Combine the vehicle bracket and the control unit bracket and secure them by tightening them together with the vehicle bolt (reuse). Pay attention to the location of each bracket.

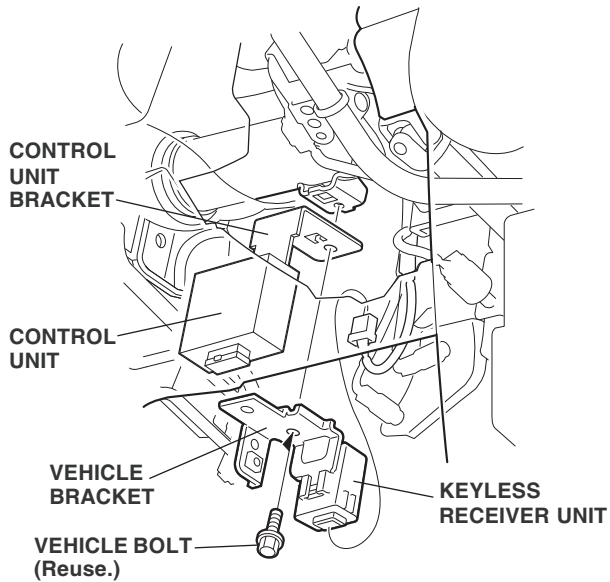

With Security System

- Combine the security system bracket and the control unit bracket and secure them by tightening them together with the vehicle bolt (reuse). Pay attention to the location of each bracket.

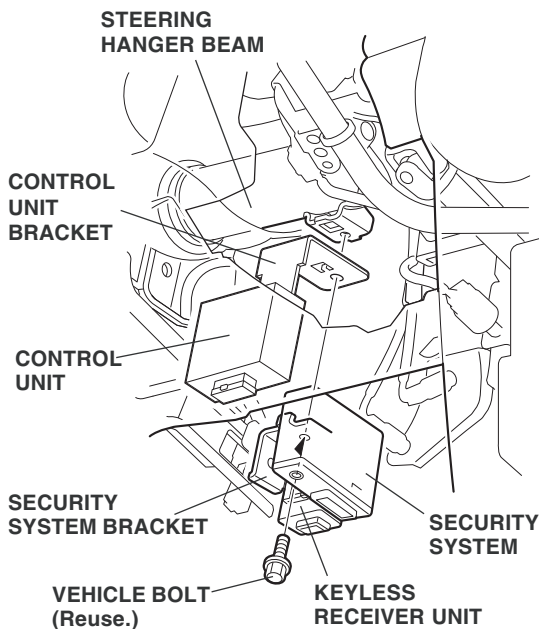

- Attach the fuse label (OPTION FUSE 7.5A/5A) to each of the fuse cases of the control unit harness. Remove the blue tape from the vehicle harness, free the vehicle 10-pin connector, and connect it to the 10-pin connector on the control unit harness.

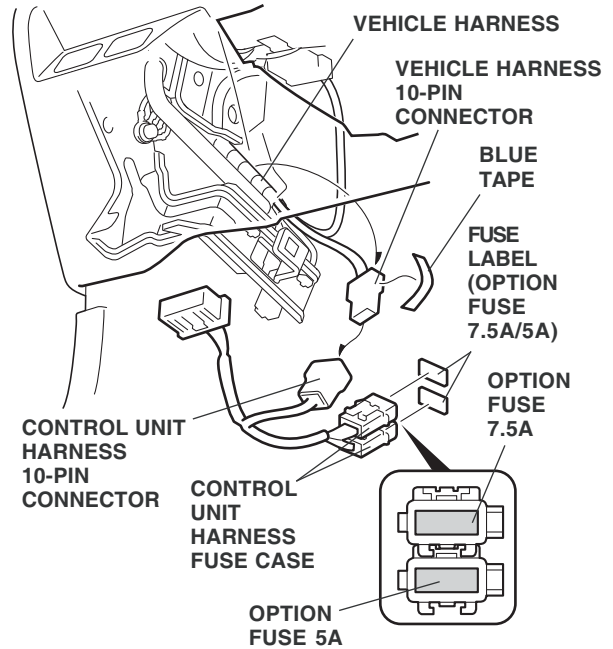

- Slide the control unit harness fuse case onto the vehicle harness coupler holder.

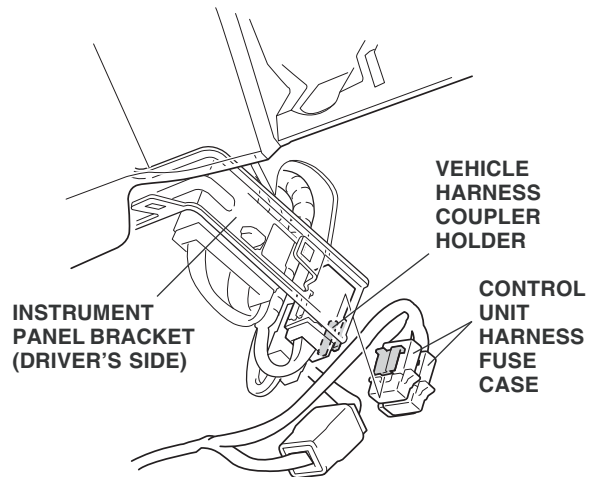

19. Plug the control unit harness 12-pin connector into the control unit.

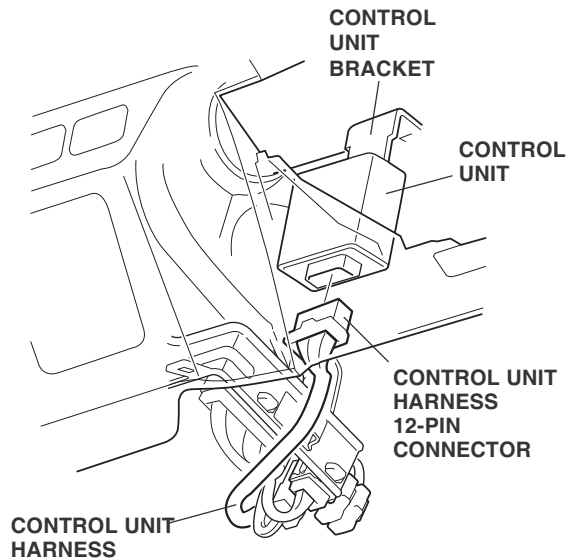

20. Secure the control unit harness to the instrument panel bracket with a wire tie.

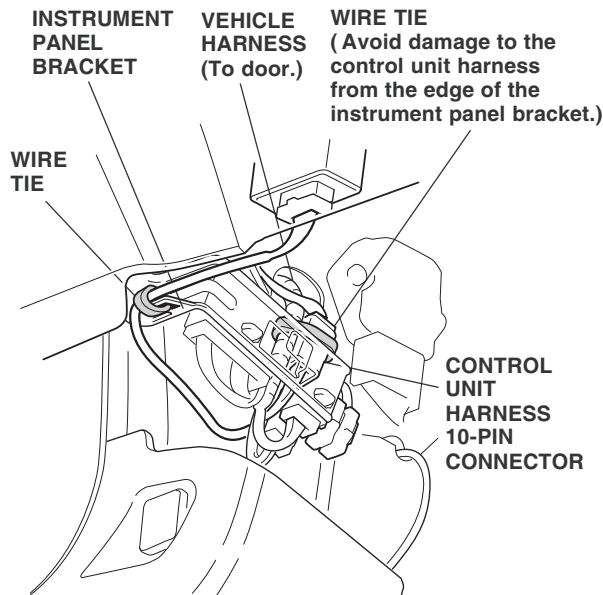

21. Secure the 10-pin connector connected in step 17 to the vehicle harness with a wire tie.

NOTE: When installing the wire tie, do not damage the control unit harness with the edge of the instrument panel bracket.

Installing the Trailer Hitch

22. Slide the four 12 x 135 mm bolts into the right and left stays.

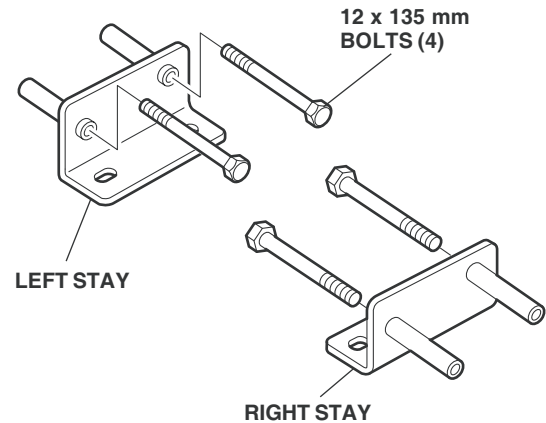

23. Slide the right and left stays into the inboard side of the right and left rear frame rails.

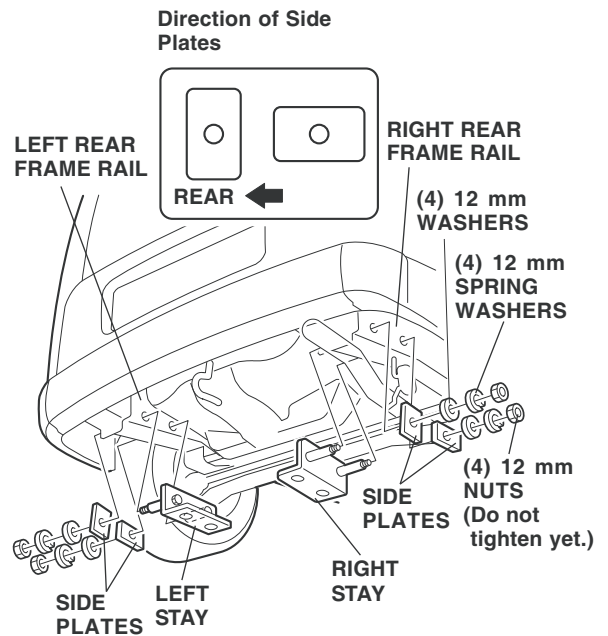

24. Slide the side plates onto the 12 x 135 mm bolts in the direction shown, then install the four 12 mm washers, four 12 mm spring washers, and four 12 mm nuts on the ends of the 12 x 135 mm bolts. Do not tighten the nuts yet.

25. With the help of an assistant, position the trailer hitch on the right and left stays and align the holes. Install the four 12 x 35 mm bolts, eight 12 mm washers, four 12 mm spring washers, and four 12 mm nuts, but do not tighten the bolts yet.

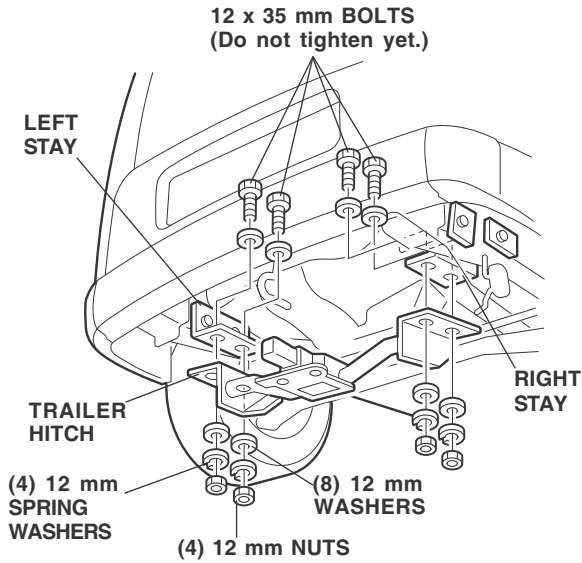

26. Insert the U-bolt around the tie-down hook and into the holes in the plate. Install an 8 mm washer, an 8 mm spring washer, and an 8 mm nut on each end. But do not tighten the nuts yet.

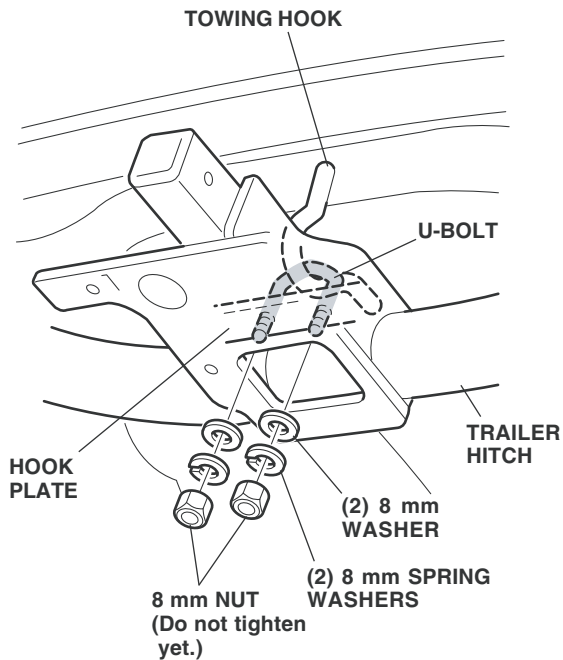

27. Torque all bolts and nuts to their specified torques in the order shown.

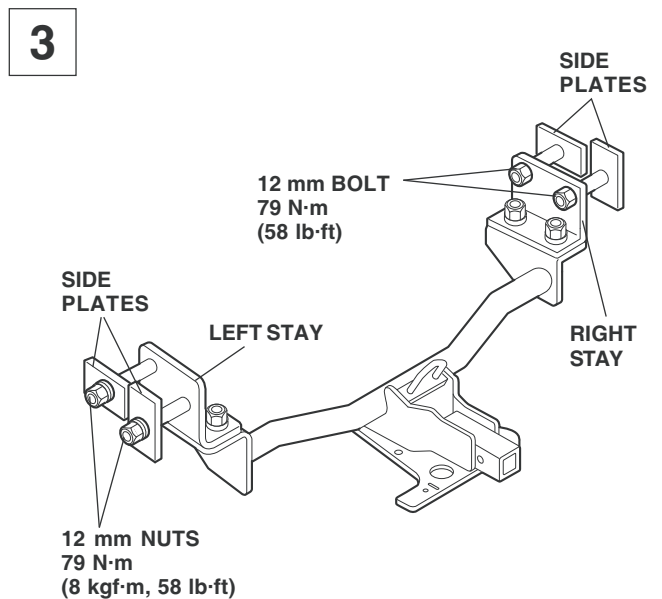
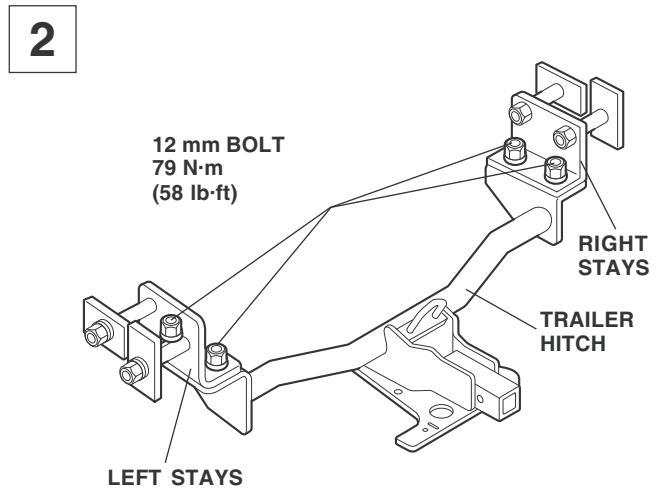
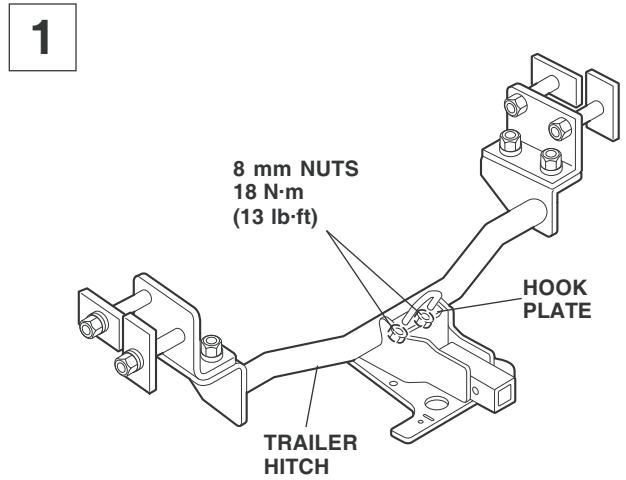

- Slide the ball mount into the trailer hitch. Align the holes in the trailer hitch with the holes in the ball mount, then insert the retaining pin into the holes. Secure the retaining pin with the retaining clip.

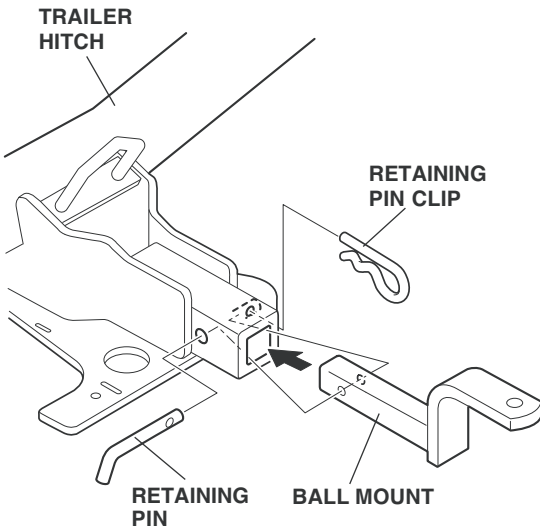

- Route the socket harness 4-pin connector along the trailer hitch to the hitch plate.

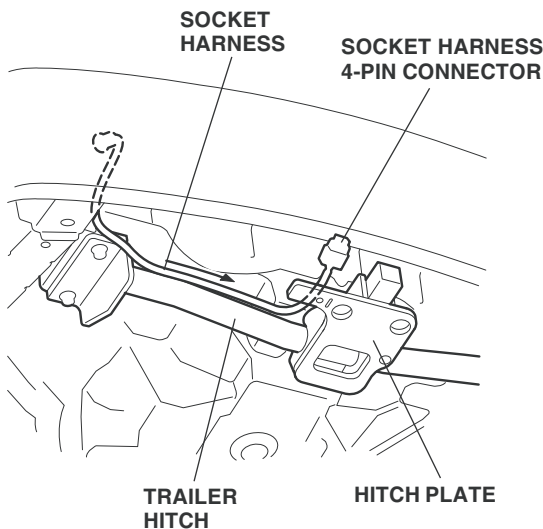

- Install the connector bracket on the socket harness 4-pin connector, and secure them to the trailer hitch with the flange bolt and flange nut. Route the trailer harness above the trailer hitch.

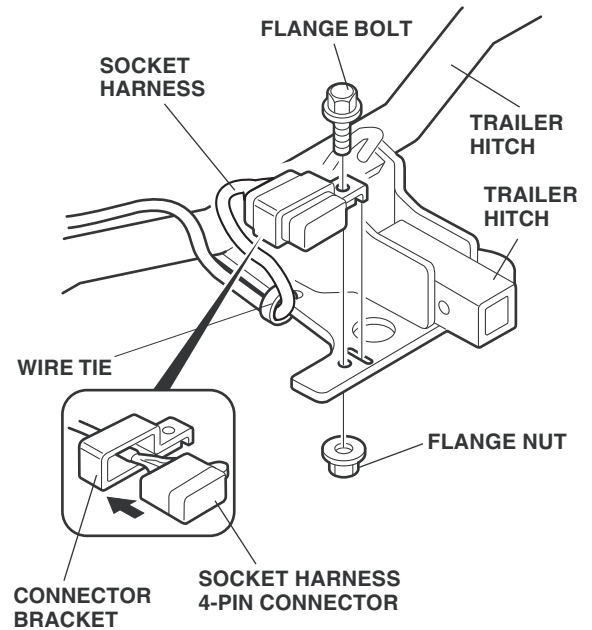

- Secure the socket harness to the trailer hitch with one wire tie.
- Secure the socket harness to the trailer hitch and to the vehicle panel with four wire ties in the areas shown.

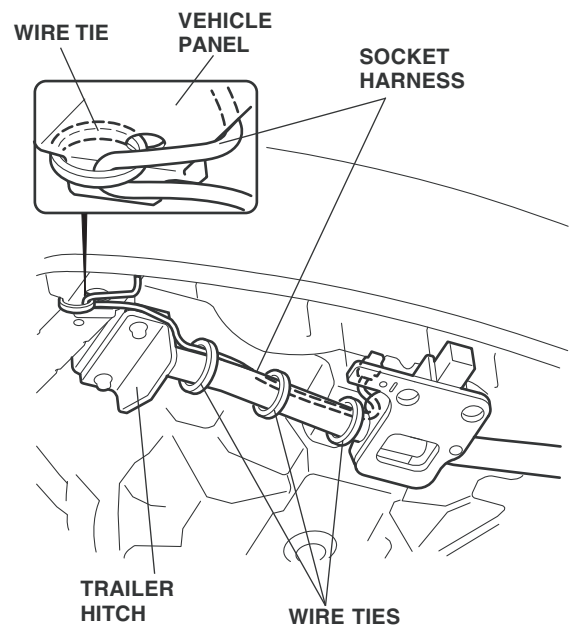

33. Check that all wire harnesses are routed properly and all connectors are plugged in.
34. Reinstall all removed parts.
35. Reconnect the negative cable to the battery.
36. Enter the customer's radio anti-theft code, and reset the radio station presets.
37. Reset the clock.

NOTE: When the battery is disconnected, the driver's window AUTO function is disabled.

38. Start the engine. Push down on the driver's window switch until the window is fully open.
39. Pull up on the driver's window switch fully to close the window completely, then hold the switch for 2 seconds or more.
40. Test the window AUTO function.

NOTE: After about 620 miles (1,000 km) of use, retighten the bolts and nuts to the specified torque.

Installing the Receiver Cover

Whenever you remove the retaining pin clip, the retaining pin, and the ball mount, securely store them in the cargo area. Then press the receiver cover into the opening at the end of the trailer hitch. When you reinstall the ball mount, store the receiver cover in the cargo area.

